

DIN EN 22 568

PROFI HSS Ms
code 281 XXX

PROFI HSSE
code 290 XXX

PROFI HSSE
code 295 XXX

PROFI HSSE VA
code 300 XXX

PROFI HSSE VA-NT
code 301 XXX

Závitové kruhové čelisti Circular dies Schneideisen Плашки

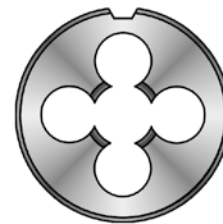
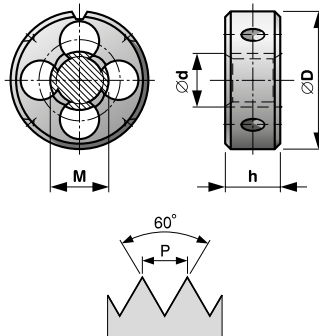

M Metrický závit ISO DIN 13
Standard metric thread ISO DIN 13
Metrische Regelgewinde ISO DIN 13
Метрическая резьба ISO DIN 13

Lícování: 6g / Tolerance: 6g /
Toleranz: 6g / Подгонка: 6g



2P

	P	ØD	h	S		code ^{x)}
M 2	0,4	16	5	4	1,93	XXX 020
M 2,2	0,45	16	5	4	2,13	XXX 022
M 2,5	0,45	16	5	4	2,43	XXX 025
M 3	0,5	20	5	4	2,92	XXX 030
M 3,5	0,6	20	5	4	3,41	XXX 035
M 4	0,7	20	5	4	3,91	XXX 040
M 5	0,8	20	7	4	4,90	XXX 050
M 6	1	20	7	4	5,88	XXX 060
M 7	1	25	9	4	6,88	XXX 070
M 8	1,25	25	9	5	7,87	XXX 080
M 9	1,25	25	9	5	8,87	XXX 090
M 10	1,5	30	11	5	9,85	XXX 100
M 11	1,5	30	11	5	10,85	XXX 110
M 12	1,75	38	14	5	11,83	XXX 120
M 14	2	38	14	5	13,82	XXX 140
M 16	2	45	18	5	15,82	XXX 160
M 18	2,5	45	18	5	17,79	XXX 180
M 20	2,5	45	18	5	19,79	XXX 200
M 22	2,5	55	22	5	21,79	XXX 220
M 24	3	55	22	6	23,76	XXX 240
M 27	3	65	25	6	26,76	XXX 270
M 30	3,5	65	25	7	29,73	XXX 300
M 33	3,5	65	25	8	32,73	XXX 330
M 36	4	65	25	9	35,70	XXX 360
M 39	4	75	30	8	38,70	XXX 390
M 42	4,5	75	30	9	37,50	XXX 420
M 45	4,5	90	36	8	44,69	XXX 450
M 48	5	90	36	8	47,66	XXX 480
M 52	5	90	36	9	51,66	XXX 520

x) 261 XXX - HSS Ms - na mosaz / brass / Messing / латунь

x) 290 XXX - HSSE

x) 295 XXX - HSSE s lamačem třísek / with spiral point / mit Schälanschnitt / с ломателем стружек

x) 300 XXX - HSSE VA - na nerez / stainless steel / Rostfreistähle / нержавеющей

x) 301 XXX - HSSE VA-NT - na nerez - nitridace / stainless steel - nitration / Rostfreistähle - Nitrierung / нержавеющей - нитрирование

Materiál: HSS; HSSE, HSSE
VA-NT - dle požadavku
Provedení: závit lapovaný
Závit: pravý

Material: HSS; HSSE, HSSE
VA-NT - on request
Execution: lapped thread
Thread: right-hand

Werkstoff: HSS; HSSE,
HSSE VA-NT - nach dem
Anspruch
Ausführung: geläpptes Ge-
winde
Gewinde: rechts

Материал: HSS; HSSE,
HSSE VA-NT - по заказу
Изготовлено: резьба
шлифованная
Резьба: правая

 **BUČOVICE
TOOLS a.s.**

DIN EN 22 568

PROFI HSS Ms
code 261 XXX

PROFI HSSE
code 290 XXX

PROFI HSSE
code 295 XXX

PROFI HSSE VA
code 300 XXX

PROFI HSSE VA-NT
code 301 XXX

Závitové kruhové čelisti Circular dies Schneideisen Плашки

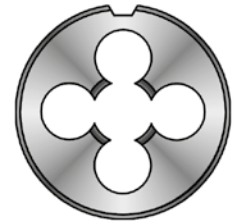
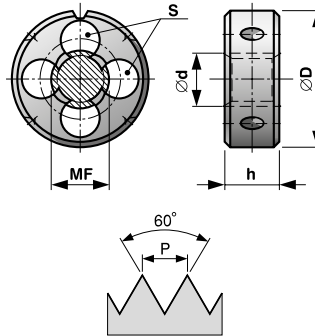

Jemný metrický závit ISO DIN 13
Fine metric thread ISO DIN 13
Metrische Feingewinde ISO DIN 13
Мелкая метрическая резьба ISO DIN 13

Licování: 6g / Tolerance: 6g /
Toleranz: 6g / Подгонка: 6g



2P

MF

	P	ØD	h	S		code ^{x)}
MF 2,5	0,35	16	5	4	2,44	XXX 026
MF 3	0,35	20	5	4	2,94	XXX 031
MF 3,5	0,35	20	5	4	3,44	XXX 036
MF 4	0,5	20	5	4	3,93	XXX 041
MF 4,5	0,5	20	5	4	4,43	XXX 046
MF 5	0,5	20	5	4	4,93	XXX 051
MF 5,5	0,5	20	5	4	5,43	XXX 056
MF 6	0,75	20	7	4	5,91	XXX 061
MF 7	0,75	25	9	4	6,90	XXX 071
MF 8	1	25	9	5	7,87	XXX 081
MF 8	0,75	25	9	5	7,90	XXX 082
MF 9	1	25	9	5	8,88	XXX 091
MF 9	0,75	25	9	5	8,90	XXX 092
MF 10	1,25	30	11	5	9,86	XXX 101
MF 10	1	30	11	5	9,88	XXX 102
MF 10	0,75	30	11	5	9,90	XXX 103
MF 11	1	30	11	5	10,88	XXX 111
MF 11	0,75	30	11	5	10,91	XXX 112
MF 12	1,5	38	10	5	11,85	XXX 121
MF 12	1,25	38	10	5	11,86	XXX 122
MF 12	1	38	10	5	11,88	XXX 123
MF 14	1,5	38	10	5	13,85	XXX 141
MF 14	1,25	38	10	5	13,86	XXX 142
MF 14	1	38	10	5	13,88	XXX 143
MF 15	1,5	38	10	5	14,85	XXX 151
MF 15	1	38	10	5	14,88	XXX 152
MF 16	1,5	45	14	5	15,85	XXX 161
MF 16	1	45	14	5	15,88	XXX 162
MF 17	1,5	45	14	5	16,85	XXX 171
MF 17	1	45	14	5	16,88	XXX 172
MF 18	2	45	14	5	17,82	XXX 181
MF 18	1,5	45	14	5	17,85	XXX 182
MF 18	1	45	14	5	17,88	XXX 183
MF 20	2	45	14	5	19,82	XXX 201
MF 20	1,5	45	14	5	19,85	XXX 202
MF 20	1	45	14	5	19,88	XXX 203
MF 22	2	55	16	5	21,82	XXX 221
MF 22	1,5	55	16	5	21,85	XXX 222
MF 22	1	55	16	5	21,88	XXX 223
MF 24	2	55	16	6	23,82	XXX 241
MF 24	1,5	55	16	6	23,85	XXX 242
MF 24	1	55	16	6	23,88	XXX 243
MF 25	1,5	55	16	6	24,85	XXX 251
MF 26	1,5	55	16	6	25,85	XXX 261
MF 27	2	65	18	6	26,82	XXX 271
MF 27	1,5	65	18	6	26,85	XXX 272
MF 27	1	65	18	6	26,88	XXX 273
MF 28	2	65	18	6	27,82	XXX 281
MF 28	1,5	65	18	6	27,85	XXX 282
MF 30	2	65	18	6	29,82	XXX 301
MF 30	1,5	65	18	6	29,85	XXX 302
MF 30	1	65	18	6	29,88	XXX 303

x) 261 XXX - HSS Ms - na mosaz / brass / Messing / латунь

x) 290 XXX - HSSE

x) 295 XXX - HSSE s lamačem třísek / with spiral point / mit Schälanschnitt / с ломателем стружек

x) 300 XXX - HSSE VA - na nerez / stainless steel / Rostfreistähle / нержавейка

x) 301 XXX - HSSE VA-NT - na nerez - nitridace / stainless steel - nitration / Rostfreistähle - Nitrierung / нержавейка - нитрирование



**BUČOVICE
TOOLS a.s.**

Materiál: HSS; HSSE, HSSE
VA-NT - dle požadavku
Provedení: závit lapovaný
Závit: pravý

Material: HSS; HSSE, HSSE
VA-NT - on request
Execution: lapped thread
Thread: right-hand

Werkstoff: HSS; HSSE,
HSSE VA-NT - nach dem
Anspruch
Ausführung: geläpftes Ge-
winde
Gewinde: rechts

Материал: HSS; HSSE,
HSSE VA-NT - по заказу
Изготовлено: резьба
шлифованная
Резьба: правая